

trilent35 system

Harris Kirshenbaum

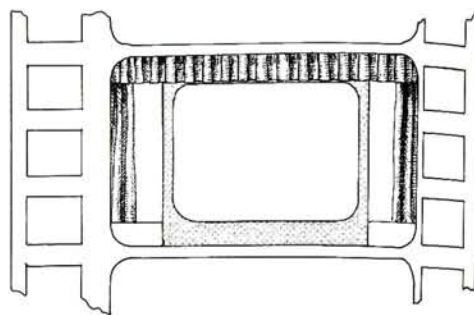

The 35mm filmmaker has long faced a difficult artistic problem in shooting feature films for both theatrical and television release. The standard Academy aspect ratio of 1.33:1 was outdated with the advent of wide screen, which came about in order to make films for theatres unusable on television as well as to give theatre-going an advantage over TV-viewing. The standard non-anamorphic wide screen picture seen in theatres today at a ratio of 1.85:1 requires that 25 per cent of the film frame not appear at all. In composing that frame, the cameraman must leave extra head and leg room so that important parts of the picture do get on the screen. But the square TV screen uses the full height of the frame, and the screen being smaller, requires tighter composition to be effective. Essentially, both systems suffer because of limitations imposed by the other, and the cameraman is faced with constant decisions as to whether to favour the theatrical or TV frame, with directors wanting both to be right.

One solution that has been used in the past is the "hard matte" in the camera, which cuts the frame area down to a more rectangular 1.66:1. Now the projectionist cannot cut off important picture area, and the two frame heights are closer together. But in this way, 25

per cent of the film area is left unexposed, and that 25 per cent is really not used anyway.

After dealing with the problem for many years, Canadian cameraman Miklós Lente CSC, came up with an idea that not only corrects the artistic problems inherent in shooting for both screen shapes, but also does away with that 25 per cent wasted footage. The idea has developed into a system and has patent applications pending under the name **TRILENT 35**, which is a 35mm non-anamorphic wide screen picture with 1.66:1 frame ratio, with the frame placed on 3 perforations rather than the present four. The frame size is 22 by 13.2mm, and the most important aspect is that *no* change is made in the quality of the image on the theatre screen. Exactly the same negative area composes each frame, the film not used is that area which does not appear on the screen. The **TRILENT 35** system has been in development for some six months with the co-operation of Arnold and Richter of Munich and the Arriflex Corporation of America.

Naturally, the rate of 24 frames per second is maintained. The equipment is slowed down to a running speed of 67.5 feet per minute from 90 fpm. The shorter frames are 1mm apart and are perfectly compatible with modern splic-

ing equipment. Convertible equipment is currently being built, and Lente hopes to have the system in use by the end of this summer.

There are great artistic advantages to the filmmaker using **TRILENT**, and the additional advantage of a 25 per cent saving in raw stock, processing and workprint costs is the bonus of the whole idea.

Camera

Cameras will be modified to run the film slower (67.5 fpm), and to pull down three perforations of film instead of four. A new viewfinder groundglass will have only two frame indicators – a 1.85:1 theatrical, with small nicks indicating the TV frame. As the camera runs slower, it will be quieter. A 400 foot load will run 25 per cent longer, or 5 minutes 30 seconds. This is most important considering the new hand-held cameras are using 400 foot magazines as the best size-weight combination and require frequent re-load breaks. The first converted camera will be an Arri 2C. Once it's operational a 35BL will be converted, and later a studio camera. Plans call for a **TRILENT** conversion kit to be available which will allow a technician to make the changes in a short

Trilent 35 Viewfinder Markings for wide screen format and TV Safety Area.

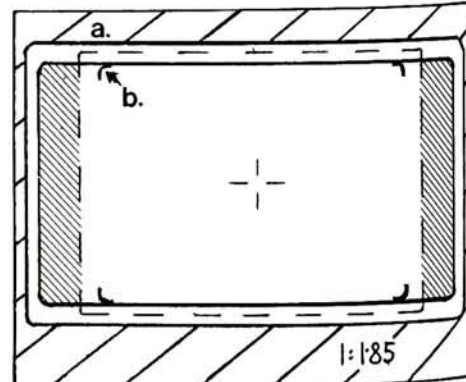
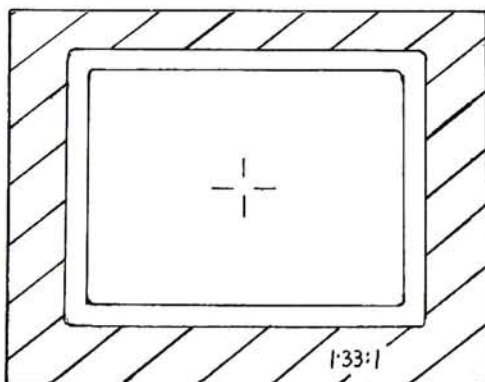
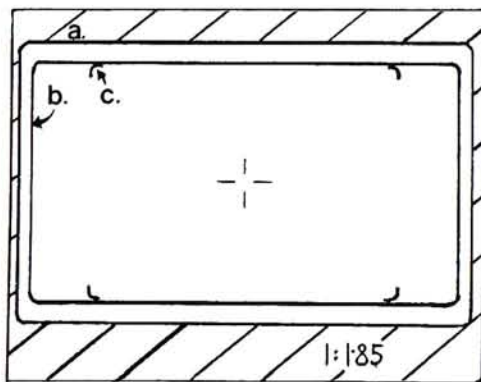

Shaded Preview Area

a. *Trilent Camera Aperture (1.66:1)*
13.2 x 22mm

b. *Projector Aperture (1.85:1)* 11.3 x 20.9mm

c. *TV Safe Action Area (1.33:1)* 11.3 x 15mm

a. Projector Aperture

b. *TV Safe Action Area*

TV Transmitted Area (Dotted line)

Out of the picture composition, only the shaded area is lost in TV transmission.

period of time.

Sound

Sound will be recorded in the standard way, and changes begin at the transfer stage. The 35mm magnetic is also slowed to 67.5 fpm, generating a saving in material here as well. The advantage of **TRILENT** to the sound department is that with the frame area being the same height for theatrical and TV, it is no longer necessary to have the boom microphone an extra 2 or 3 feet higher over the actor's head to keep the mike out of the TV frame. Production time is cut since less time is spent hiding mikes. Sound quality will improve by much more than the amount lost by the slower running speed. Objections to the slower speed are squelched by converting the speed to inches per second and finding it to be 13.5, which is more than adequate for full frequency response, with modern recording hardware and materials. This speed is twice as fast as 16mm, yielding much better response than the smaller gauge.

Soundmix Ltd. of Toronto will have a gearshift built into the transfer, dubbing and mixing equipment to convert between **TRILENT** and 4-perforation systems, and apparently this conversion is not very complicated or expensive.

Editing

As both sound and picture run at the same speed, no change is caused in the editing process. Modular 35mm editing tables are easily converted, and KEM in Germany is designing conversion modules that will allow simple change-over. KEM was chosen for first modifications because their table is more modular than the others. Changes will involve only the running speed and the prism, which will have more sides and therefore deliver a superior image to the editing screen. The table will run quieter as it's slower. The conversion kit will be available for purchase or lease.

Conversion of the 35 Moviola will be more difficult, but not impossible. The intermittent drive mechanism can be changed over, and research in that area will begin if demand is sufficient.

Projection

Realistically, theatres cannot be expected to change over projection equipment to handle **TRILENT** before it is proven and a large percentage of films are being shot with the system, so in the beginning an optical transfer will space out the frames onto 4-perforation standard distance for release prints that can be shown on standard projectors. Film Optical Ltd. of Toronto are planning modifications to a liquid gate optical printer to make the printing master, and additional costs incurred will be a small part of the overall saving.

Later, as the system catches on and

distributors realize they can cut release print costs by 25 per cent and shipping costs by some percentage, projectors will be in demand. **TRILENT** was presented to RCA just as they were beginning development of a new projector which uses an electronically controlled stop-and-go motor instead of the costly and complicated intermittent movement currently in use. This projector will require only a small additional circuit and switch to convert between 2,3 or 4 perforation pulldown, and the associated running speed.

There are additional advantages to the **TRILENT 35** system, which will become available as further developments occur:

With an optional additional change to the camera, an extra 1/4-stop in exposure is available. Because less film is pulled down between each frame exposure, less time is taken to achieve the movement. The film will stay in the gate slightly longer, so the shutter can be changed from its standard 180 degree opening to a 225 degree opening. As faster films and lenses become available, this 1/4-stop may be considered even more important for low light shooting.

Another future development is the thinner, polyester-based film stock. Currently there are problems with this material, but once it is available, the 400 foot magazines on new handheld cameras will hold 575 feet of film. At 67.5 fpm, that becomes the equivalent of 862 feet of film for a running time of 9.5 minutes per load. Over twice the current 4.5 minutes.

For "TV only" productions, a **TRILENT** negative or camera original has 3 times the area of a 16mm frame, yielding three times the picture resolution. By comparison, standard 35 has 4.6 times the area of 16. The saving in film costs may make it possible to shoot TV programmes in 35. Commercials have an advantage as well, since there is more side to side area in which to optically shift the image in post-production.

The final step in the development of **TRILENT** will be the anamorphic version called **TRISCOPE**, which is now in the planning stages. The final result is a 2:1 ratio, 4-perforation pulldown, Cinemascope-type release print. All production work is done in **TRILENT**, with only a 1.45:1 compression or "squeeze" ratio, and the 4-perforation version is created at the release-print stage, adding a further anamorphic distortion. **TRISCOPE** will require special lenses which will be built. The minimal compression will mean that post-production equipment need not be converted at all, since the image will appear only slightly distorted. The converted KEM tables will have an additional lens for the **TRISCOPE** picture.

Laboratories need make no special

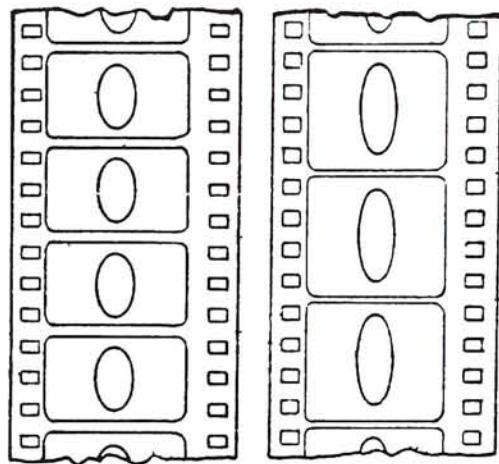

conversions to handle **TRILENT** footage, with the exception of acquiring a 3-perforation projector to check prints. Labs may object to the system on the ground that they will be processing and printing less footage per project, but if the system enables only one or two more films to be produced in its first year, surely compensation will have been made.

TRILENT was not designed to compete with 16mm in any area. It was arrived at as the solution to the artistic problem of trying to compose one picture to be suitable for both rectangular and square screens. The cost saving is an additional advantage and makes the system that much more interesting. Low budget features may save an estimated \$10,000 even considering the cost of making the optical printing master. That money, invested in increasing production values in other areas, just may be the helping hand that low budget films have been needing to increase their markets.

All equipment necessary for **TRILENT** production will eventually be available from Mike Lente Films Ltd., or a new company to be called **TRILENT Systems**. Cinema Canada will publish further developments in the system, and we will attempt to answer any written questions you may have.

Possible Shutter Conversion

